

## **BAGGERS GP TECHNICAL SPECIFICATIONS**

The following rules are intended to give freedom to modify or replace some parts in the interest of safety, research and development and improved competition between various motorcycle concepts.

### **EVERYTHING THAT IS NOT AUTHORIZED AND PRESCRIBED IN THIS RULE IS STRICTLY FORBIDDEN**

#### **1. Motorcycle specifications**

All Years                      Harley-Davidson FL Touring

All Years                      Indian Bagger or Touring

#### **2. Engine configurations and displacement capacities**

##### **Harley-Davidson Motorcycles:**

- A. Originally equipped air-cooled pushrod V-Twin engines, maximum displacement of 131ci. normally aspirated.
- B. S&S or Jim's air-cooled pushrod Twin Cam engines w/MSO are acceptable up to 131ci. normally aspirated.
- C. Forced induction air-cooled pushrod V-Twin engines allowed with maximum displacement of 107ci.

##### **Indian Motorcycles:**

- A. Originally equipped with a water-cooled V-Twin Engine, maximum displacement of 112ci. normally aspirated.
- B. Originally equipped with an air-cooled pushrod V-Twin Engine, maximum displacement of 131ci. normally aspirated.
- C. Forced induction air-cooled pushrod V-Twin engines allowed with maximum displacement of 111ci.

#### **3. Balancing various motorcycle concepts**

In order to equalize the performance of motorcycles used in the BRL, a system of performance enhancements or restrictions have been developed

(such as minimum weight, air restrictor or REV limit may be applied according to their respective racing performances). The decision to apply a balancing system to a motorcycle will be taken by the Bagger Racing League officials based on decisions made by the BRL officials at any time deemed necessary to ensure fair competition.

#### **4. Minimum weight**

**Harley Davidson: Minimum weight - 500 lbs.**

**Indian Air Cooled Pushrod: Minimum weight - 500 lbs.**

**Indian Challenger: Minimum weight - 635 lbs**

At any time of the event, the weight of the whole motorcycle (including the tank and its contents) must not be lower than the minimum weight.

There is no tolerance on the minimum weight of the motorcycle.

During the final technical inspection at the end of the race, the selected motorcycles will be weighed in the condition they finished the race, and the established weight limit must be met in this condition. Nothing may be added to the motorcycle. This includes all fluids.

During the practice and qualifying sessions, riders may be asked to submit their motorcycle to a weight control. In all cases, the rider must comply with this request.

The use of ballast is allowed to stay over the minimum weight limit and may be required due to the handicap system. The use of ballast and weight handicap must be declared to the Technical Director at the preliminary checks.

#### **5. Numbers and number plates**

The background colors and figures (numbers) for Baggers may be any color but must be strongly contrasting.

#### **6. Fuel**

**All competitors must use TBD. Fuel Specification T4.**

#### **7. Tires**

A. Tires from any manufacturer are permitted.

#### **8. Engine**

## 9. Fuel system

- A. The original equipped fuel system must be used.
- B. Air funnels, throttle bodies and airbox may be altered or replaced.
- C. Air and air/fuel mixture must go to the combustion chamber exclusive through the throttle bodies/ Intake manifolds.

## 10. Cylinder Head

**Air Cooled Pushrod Engines:** Cylinder heads may be altered or replaced.

**Water cooled engines:** Cylinder heads must be the originally fitted part with the following modifications allowed:

- A. The cylinder head must begin as a finished production part using originally equipped materials and castings.
- B. Porting and polishing of the cylinder head normally associated with individual tuning such as gas flowing of the cylinder head, including the combustion chamber is allowed. Epoxy may be used to shape the ports.
- C. The throttle body intake insulators may be modified.
- D. The compression ratio is free.
- E. The combustion chamber may be modified.
- F. Valves may be modified.
- G. Valve seats can be modified or replaced for repair.
- H. Valve guides may be modified.
- I. Valves must remain in the homologated location and at the same angle.
- J. Rocker arms (if any) may be modified.
- K. The exhaust air bleed system may be blocked.
- L. Valve springs may be modified.

## 11. Camshaft

- A. Camshafts may be altered or replaced.

## 12. Cam sprockets or cam gears

- A. Camshaft sprockets, pulleys or gears may be altered or replaced to allow degreeing of the camshafts.
- B. The cam chain or cam belt tensioning device(s) can be modified or changed.

## 13. Cylinders

- A. Normally aspirated air-cooled pushrod engines may increase the bore to a maximum total displacement of 131ci.
- B. Normally aspirated water-cooled engines are limited to 112ci.
- C. Forced induction engines: Harley Davidson air-cooled 107 ci./ Indian air-cooled 111 ci.

#### **14. Pistons, rings, pins and clips.**

- A. Air cooled pushrod V-Twin engines: May be modified.
- B. Water cooled engine: must be factory or factory option homologated parts.

#### **15. Connecting rods**

- A. Connecting rod may be altered or replaced.
- B. Connecting rod bolts are free but must be of the same weight or heavier, and of the same material as the original bolt or of higher specific weight material.

#### **16. Crankshaft**

Only the following modifications can be made to the crankshaft:

- A. Stroke may be modified on air cooled pushrod V-Twin engines. Water cooled to remain the same as the originally fitted and homologated part.
- B. Bearing surfaces may be polished.
- C. Surface treatments may be applied to the crankshaft.
- D. Balancing is allowed.

#### **17. Crankcase / Gearbox housing**

- A. Crankcases must be the originally fitted part with only the following modifications allowed. If the crankcases have an integral cylinder, then the top face of the cylinder may be ground to adjust deck height. Oil Spray nozzles may be modified. Air Cooled Pushrod Engines: may modify case for camshaft clearance, crank balance shaft removal and tapered crankshaft bearing upgrades.
- B. No other modifications are allowed (including painting & polishing).
- C. Only the original or an approved sump Oil-pan (sump) and oil pick up can be used.
- D. Oil breather cover must remain as original, but the internal breather/damper plate can be modified or replaced.
- E. Oil tank breathers are acceptable and may run through an external catch can but all exits are advised to be routed to the intake system.

#### **18. Lateral covers and protection**

- A. Lateral (side) covers may be altered, modified or replaced (excluding pump covers). If altered or modified, the cover must have at least the same resistance to impact as the original one. If replaced, the cover must be made in material of the same or higher specific weight and the total weight of the cover must not be less than the original one.
- B. All lateral covers/engine cases containing oil, and which could be in contact with the ground during a crash, must be protected by a second cover made from metal such as aluminum alloy, stainless steel, steel or titanium.
- C. All drain and fill plugs must be lock wired (safety wired). The use of clips is not permitted. External oil filter(s), screws and bolts that enter an oil cavity must be safety wired (i.e. on crankcases) or the oil filter may optionally have a secondary retention mechanism.

## **19. Transmission / Gearbox**

- A. The layout of the transmission shafts must be the same as on the homologated motorcycle.
- B. The gear design and material are free.
- C. Final drive belt systems may be converted to chain type systems.

## **20. Clutch**

- A. Aftermarket or modified clutches are permitted (including plates/springs/baskets etc.).

## **21. Oil pumps, cam plates and oil lines**

- A. The oil pump and camplate may be modified or replaced.
- B. Oil lines may be modified or replaced. Oil lines containing positive pressure, if replaced, must be of braided reinforced construction with swaged or threaded connectors.

## **22. Cooling System**

- A. The only liquid engine coolants permitted is water.
- B. Additional radiators or oil coolers may be added.
- C. The original oil/water heat exchanger may be modified, replaced or removed.

## **23. Airbox**

- A. The airbox may be modified or replaced.

- B. Airboxes should be designed to retain oil from the crankcases in the event of engine failure or tip-over.
- C. Where breather or overflow pipes are fitted, they must discharge via existing outlets. Catch cans may be used but the original closed system must be retained.

## **24. Fuel supply**

- A. Fuel lines from the fuel tank up to the injectors (fuel hoses, delivery pipe assembly, joints, clamps, fuel canister) may be replaced and must be in such a way that they are protected from crash damage.
- B. Quick connectors or dry break connectors may be used.
- C. Fuel vent lines may be replaced.
- D. Fuel filters may be added.

## **25. Exhaust system**

- A. Exhaust pipes, catalytic converters and silencers may be altered or replaced from those fitted to the homologated motorcycle. Catalytic converters may be removed.
- B. For safety reasons, the exposed edge(s) of the exhaust pipe(s) outlet(s) must be rounded to avoid any sharp edges.
- C. Wrapping of exhaust systems is allowed.
- D. The noise limit for Baggers will be 117dB/A measured at 3000RPM.(with a 3dB/ A tolerance after the race only).

## **26. Engine control system**

- A. The engine control system (ECU)
  - a. Original system as homologated, with or without software change.
  - b. Approved aftermarket systems: Thundermax, S&S, Dyno Jet / PV, Techno Research and TTS.

Central unit (ECU) may be relocated.

The original sensors may not be replaced or modified. No additional sensors may be added to the machine for data collection.

No extra sensors may be added for control strategies except the throttle bodies, fuel pressure, oil pressure, lambda sensor and shift rod sensor.

No external module may add traction control strategies. The modules may only connect to the fuel injectors, ignition coils, lambda sensor, power supply and “piggyback the Throttle Position, Gear and RPM signals”. Lambda closed loop/ auto tuning is permitted.

Other additional electronic hardware equipment not on the original homologated motorcycle cannot be added with the exceptions noted below

- c. Resistors/load/electronic hardware may be added to replace the parts of the electrical system that have been removed (including lights, lambda sensors, etc.) to prevent ECU errors, and also includes needed wiring for throttle bodies and or turbo units.

Telemetry is not allowed.

No remote or wireless connection to the bike for any data exchange or setting is allowed whilst the engine is running, or the bike is moving.

Harness:

- d. The key/ignition lock may be relocated, replaced or removed.
- e. Cutting and removal of excess and unused wiring in the original wiring harness is allowed.

A lap timer may be fitted. GPS lap timers may be used. The lap timer may only be connected to the machine with a power and ground connection. Data collection from the machines sensors or ECU is allowed. Data collection by the lap timer by way of GPS and internal IMU is permitted.

Spark plugs may be replaced.

Battery is free.

## **27. Generator, alternator, electric starter**

- A. The stator/coil must be the originally fitted parts with no modification allowed.
- B. Motorcycles should self-start on the starting grid in neutral. Push-starting on the starting grid is not allowed, however start line Officials may push start the motorcycle if necessary (in gear).

## **28. Main frame and spare motorcycle**

- A. During the entire duration of the event, each rider may only use one (1) complete motorcycle.

## **29. Frame body and rear subframe**

- A. The main frame must be the originally manufactured and fitted part.
- B. Holes may be drilled on the frame to affix approved components (i.e. fairing brackets, saddlebag relocation, steering damper mounts, engine & chassis stabilizers etc.).
- C. All motorcycles must display a vehicle identification number punched on the frame body (a proper 'legal VIN')
- D. Crash protectors may be fitted to the frame using existing points or pressed into the ends of the wheel axles.

## **30. Suspension - General**

- A. Suspension may be modified but a similar system to the homologated must be used.

## **31. Front Suspension**

- A. The front fork in whole or part may be changed.
- B. The upper and lower fork clamps (triple clamp, fork bridges) and stem may be changed or modified.
- C. A steering damper may be added or replaced.
- D. The steering damper cannot act as a steering lock limiting device.

## **32. Swing-arm (Rear Fork)**

- A. Swing-arms may be replaced or modified.
- B. A Solid Protective Cover (sharkfin) shall be fixed to the swing-arm and must always cover the opening between the lower chain run, swing-arm and the rear wheel sprocket, irrespective of the position of the rear wheel.
- C. Rear wheel stand brackets may be added to the rear fork by welding or by bolts.
- D. Brackets must have rounded edges (with a large radius). Fastening screws must be recessed.
- E. Swingarm spindle (pivot) may be modified or replaced.

## **33. Rear suspension unit**

- A. Rear suspension unit may be changed but a similar system must be used (i.e. dual or mono).
- B. Removable top shock mounts may be replaced. If replaced they must retain their general homologated geometry.

## **34. Wheels**



- A. Wheels may be replaced, and associated parts may be altered or replaced from those fitted to the homologated motorcycle.
- B. Aftermarket Wheels Must Be Made From Aluminum Alloys.
- C. The use of the following alloy materials for the wheels is not allowed: Beryllium ( $\geq 5\%$ ), Scandium ( $\geq 2\%$ ), Lithium ( $\geq 1\%$ ).
- D. Bearings, seals, and axles may be altered or replaced from those fitted to the homologated motorcycle. The use of titanium and light alloys is forbidden for wheel spindles (axles).
- E. Wheel balance weights may be discarded, changed or added to.
- F. Aluminum or steel inflation valves are compulsory.

### **Wheel Sizes Front and Rear 17-19"**

#### **35. Brakes**

- A. Front brake master cylinder may be altered or replaced.
- B. Front brake calipers may be altered or replaced.
- C. Rear brake master cylinder may be altered or replaced.
- D. Rear brake calipers may be altered or replaced.
- E. Brake pads or shoes may be altered or replaced.
- F. Brake hoses and brake couplings may be altered or replaced.
- G. Hydraulic anti-knockback systems may be fitted to the brake lines/caliper.
- H. Brake discs may be altered or replaced. Only Steel (max. carbon content 2.1wt.%) is allowed for brake discs. Alloys containing beryllium are not allowed to be used for brake calipers.
- I. ABS systems must be removed or disabled if still on motorcycle.

#### **36. Handlebars and hand controls**

- A. Handlebars, hand controls and cables may be altered or replaced from those fitted to the homologated motorcycle.
- B. Cable operated throttles (grip assembly) must be equipped with both an opening and a closing cable including when actuating a remote drive by wire grip/demand sensor.
- C. Motorcycles must be equipped with a functional ignition kill switch or button mounted on the right-hand handlebar (within reach of the hand while on the hand grips) that can stop a running engine. The button or switch must be RED.

#### **37. Footrest and foot controls**

- A. Footrests, hangers/brackets and hardware may be replaced and relocated but the hangers/brackets must either be mounted to their original frame mounting points or another location that does not require the modification of the frame.

### **38. Fuel tank**

- A. The fuel tank must be the general shape and dimension of the originally fitted and homologated part.
- B. All fuel tanks must be completely filled with fire retardant material (i.e. fuel tank foam).
- C. Fuel tanks with tank breather pipes must be fitted with no-return valves that discharge into a catch tank with a minimum volume of 250 cc made of a suitable material.
- D. Material is free.

### **39. Seat**

- A. Seat may be altered or replaced.

### **40. Fairing / Bodywork**

- A. The fairing, rear fender and body work must conform in principle to the homologated shape as originally produced by the manufacturer. Styling modifications are free. Front fender is free. Material is free. Headlights may be included even when considered external. All glass and plastic lenses should be covered by a clear vinyl or a vinyl replicating the look of the lens.
  - a. HarleyDavidson: must run a batwing fairing or Road Glide fairing. Either model fairing is acceptable regardless of the model HD motorcycle.
  - b. Indian Motorcycles: must replicate the originally fitted and homologated part
- B. The Windscreen Must Be Installed And Maybe Replaced.
- C. A lower catch/belly pan must be constructed to hold, in case of an engine breakdown, at least half of the total oil and engine coolant capacity used in the engine. Harley M8's ('17-'21) total engine has 5 qts (2.36L.) Harley Twin Cam ('99-'16) total engine has 4 qts (.89L).
- D. The saddlebags must conform in principle to the original shape as originally produced by the manufacturer. Styling Modifications are free.
- E. The inner side (next to the wheel) of the bag can be modified in shape but must remain stock size.
- F. Height may be altered a maximum of 2" in respect to the original mounting point on the subframe. Material is free.

- G. Saddlebag lids must conform in principle to the OEM dimensional spec and shape of originally fitted Touring model hard bags. Material is free.

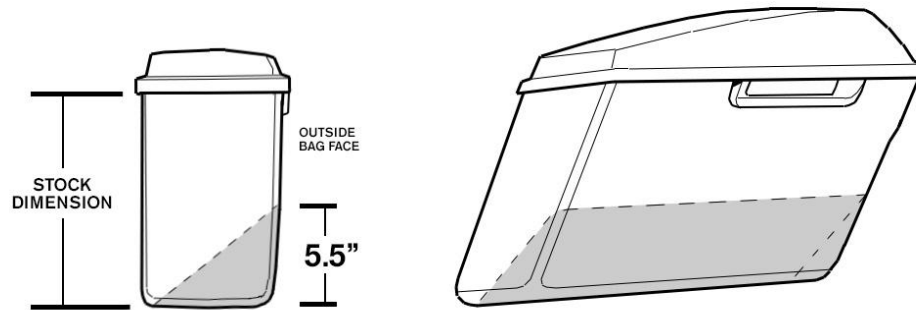

**41. The following items MAY BE altered or replaced from those fitted to the homologated motorcycle.**

- A. Any type of lubrication, brake or suspension fluid may be used.
- B. Gaskets, seals, and gasket material.
- C. Bearings (ball, roller, taper, plain, etc.) of any type or brand may be used.
- D. Fasteners (nuts, bolts, screws, etc.), but internal engine bolts must remain of standard homologated materials or materials of higher specific weight.
- E. Thread repair using inserts of different material such as helicoils and timeserts.
- F. External surface finishes and decals.

**42. The following items MAY BE removed**

- A. Instrument and instruments bracket and associated cables.
- B. Tachometer.
- C. Speedometer and associated wheel spacers.

**43. The Following Items MUST BE Removed**

- A. Rear-view mirrors.
- B. Horn.
- C. License plate bracket.
- D. Toolbox.

- E. Safety bars, center and side stand brackets welded to the main frame may be removed. If the side stand is not removed it must be held in the up position by a secondary device.

#### **44. Rider Requirements - Bagger GP Class**

- A. Bagger GP riders must be an expert plate holder.
- B. Rider must be signed off by any valid club Racing Organization.
- C. To achieve expert plates a Racer must race as an Amateur and acquire enough “points” to advance on to an Expert plate with a sanctioned race organization.

#### **45. Rider Gear Requirements - Bagger GP Class**

- A. **Helmet** – DOT full-face helmet (no flip up style). The helmet should meet SNELL or BSI certifications. The helmet should not be more than 5 years old, and it should be undamaged. Normal wear and tear from general use and transport are ok, but a helmet that has been crashed in or that has been visibly damaged will not pass tech.
- B. **Suit** – 1 or 2-piece. If it is 2-piece, it must affix together via a zipper between the jacket and the pants.
- C. **Back Protector** – An aftermarket back protector is highly recommended, back protector must be a CE-approved foam insert at the minimum.
- D. **Gloves** – Gauntlet-style glove that provides full coverage over your wrists and overlaps your leathers. Gloves should be in good condition and without holes or damage.
- E. **Boots** – Provide full ankle coverage. They may be worn under the legs of your pants only if your Race Suit pant legs are designed for this. Otherwise, your boots must fully overlap the pant legs on your suit.

For more information contact the BAGGER RACING LEAGUE.

# STUNT GP

## STUNT GP TECHNICAL SPECIFICATIONS

The following rules are intended to give freedom to modify or replace some parts in the interest of safety, research and development and improved competition between various motorcycle concepts.

### **EVERYTHING THAT IS NOT AUTHORIZED AND PRESCRIBED IN THIS RULE IS STRICTLY FORBIDDEN**

#### **1. Motorcycle specifications**

All Years	Harley-Davidson FL Touring
All Years	Indian Bagger or Touring

#### **2. Engine configurations and displacement capacities**

##### **Harley-Davidson Motorcycles:**

- D. Originally equipped air-cooled pushrod V-Twin engines, maximum displacement of 131ci. normally aspirated.
- E. S&S or Jim's air-cooled pushrod Twin Cam engines w/MSO are acceptable up to 131ci. normally aspirated.
- F. Forced induction air-cooled pushrod V-Twin engines allowed with maximum displacement of 107ci.

##### **Indian Motorcycles:**

- D. Originally equipped with a water-cooled V-Twin Engine, maximum displacement of 112ci. normally aspirated.
- E. Originally equipped with an air-cooled pushrod V-Twin Engine, maximum displacement of 131ci. normally aspirated.
- F. Forced induction air-cooled pushrod V-Twin engines allowed with maximum displacement of 111ci.

#### **3. Balancing various motorcycle concepts**

In order to equalize the performance of motorcycles used in the BRL, a system of performance enhancements or restrictions have been developed

(such as minimum weight, air restrictor or REV limit may be applied according to their respective racing performances). The decision to apply a balancing system to a motorcycle will be taken by the Bagger Racing League officials based on decisions made by the BRL officials at any time deemed necessary to ensure fair competition.

#### **4. Minimum weight**

**Harley Davidson: Minimum weight - 500 lbs.**

**Indian Air Cooled Pushrod: Minimum weight - 500 lbs.**

**Indian Challenger: Minimum weight - 635 lbs**

At any time of the event, the weight of the whole motorcycle (including the tank and its contents) must not be lower than the minimum weight.

There is no tolerance on the minimum weight of the motorcycle.

During the final technical inspection at the end of the race, the selected motorcycles will be weighed in the condition they finished the race, and the established weight limit must be met in this condition. Nothing may be added to the motorcycle. This includes all fluids.

During the practice and qualifying sessions, riders may be asked to submit their motorcycle to a weight control. In all cases, the rider must comply with this request.

The use of ballast is allowed to stay over the minimum weight limit and may be required due to the handicap system. The use of ballast and weight handicap must be declared to the Technical Director at the preliminary checks.

#### **5. Numbers and number plates**

The background colors and figures (numbers) for Baggers may be any color but must be strongly contrasting.

#### **6. Fuel**

A. All competitors must use TBD. Fuel Specification T4.

#### **7. Tires**

B. All machines must be fitted with TBD. Specification (TBD)

#### **8. Engine**

## 9. Fuel system

- D. The original equipped fuel system must be used.
- E. Air funnels, throttle bodies and airbox may be altered or replaced.
- F. Air and air/fuel mixture must go to the combustion chamber exclusive through the throttle bodies/ Intake manifolds.

## 10. Cylinder Head

**Air Cooled Pushrod Engines:** Cylinder heads may be altered or replaced.

**Water cooled engines:** Cylinder heads must be the originally fitted part with the following modifications allowed:

The cylinder head must begin as a finished production part using originally equipped materials and castings.

Porting and polishing of the cylinder head normally associated with individual tuning such as gas flowing of the cylinder head, including the combustion chamber is allowed. Epoxy may be used to shape the ports.

The throttle body intake insulators may be modified.

The compression ratio is free.

The combustion chamber may be modified.

Valves may be modified.

Valve seats can be modified or replaced for repair.

Valve guides may be modified.

Valves must remain in the homologated location and at the same angle.

Rocker arms (if any) may be modified.

The exhaust air bleed system may be blocked.

Valve springs may be modified.

## 11. Camshaft

B. Camshafts may be altered or replaced.

## **12. Cam sprockets or cam gears**

C. Camshaft sprockets, pulleys or gears may be altered or replaced to allow degreasing of the camshafts.

D. The cam chain or cam belt tensioning device(s) can be modified or changed.

## **13. Cylinders**

D. Normally aspirated air-cooled pushrod engines may increase the bore to a maximum total displacement of 131ci.

E. Normally aspirated water-cooled engines are limited to 112ci.

F. Forced induction engines: Harley Davidson air-cooled 107 ci./ Indian air-cooled 111 ci.

## **14. Pistons, rings, pins and clips.**

C. Air cooled pushrod V-Twin engines: May be modified.

D. Water cooled engine: must be factory or factory option homologated parts.

## **15. Connecting rods**

C. Connecting rod may be altered or replaced.

D. Connecting rod bolts are free but must be of the same weight or heavier, and of the same material as the original bolt or of higher specific weight material.

## **16. Crankshaft**

Only the following modifications can be made to the crankshaft:

E. Stroke may be modified on air cooled pushrod V-Twin engines. Water cooled to remain the same as the originally fitted and homologated part.

F. Bearing surfaces may be polished.

G. Surface treatments may be applied to the crankshaft.

H. Balancing is allowed.

## **17. Crankcase / Gearbox housing**

F. Crankcases must be the originally fitted part with only the following modifications allowed. If the crankcases have an integral cylinder, then the top face of the cylinder may be ground to adjust deck height. Oil Spray nozzles may be modified. Air Cooled Pushrod Engines: may modify case for camshaft clearance, crank balance shaft removal and tapered crankshaft bearing upgrades.



- G. No other modifications are allowed (including painting & polishing).
- H. Only the original or an approved sump Oil-pan (sump) and oil pick up can be used.
- I. Oil breather cover must remain as original, but the internal breather/damper plate can be modified or replaced.
- J. Oil tank breathers are acceptable and may run through an external catch can but all exits are advised to be routed to the intake system.

## **18. Lateral covers and protection**

- D. Lateral (side) covers may be altered, modified or replaced (excluding pump covers). If altered or modified, the cover must have at least the same resistance to impact as the original one. If replaced, the cover must be made in material of same or higher specific weight and the total weight of the cover must not be less than the original one.
- E. All lateral covers/engine cases containing oil, and which could be in contact with the ground during a crash, must be protected by a second cover made from metal such as aluminum alloy, stainless steel, steel or titanium.
- F. All drain and fill plugs must be lock wired (safety wired). The use of clips is not permitted. External oil filter(s), screws and bolts that enter an oil cavity must be safety wired (i.e. on crankcases) or the oil filter may optionally have a secondary retention mechanism.

## **19. Transmission / Gearbox**

- D. The layout of the transmission shafts must be the same as on the homologated motorcycle.
- E. The gear design and material are free.
- F. Final drive belt systems may be converted to chain type systems.

## **20. Clutch**

- B. Aftermarket or modified clutches are permitted (including plates/springs/baskets etc.).

## **21. Oil pumps, cam plates and oil lines**

- C. The oil pump and camplate may be modified or replaced.
- D. Oil lines may be modified or replaced. Oil lines containing positive pressure, if replaced, must be of braided reinforced construction with swaged or threaded

connectors.

## **22. Cooling System**

- D. The only liquid engine coolants permitted is water.
- E. Additional radiators or oil coolers may be added.
- F. The original oil/water heat exchanger may be modified, replaced or removed.

## **23. Airbox**

- D. The airbox may be modified or replaced.
- E. Airboxes should be designed to retain oil from the crankcases in the event of engine failure or tip-over.
- F. Where breather or overflow pipes are fitted, they must discharge via existing outlets. Catch cans may be used but the original closed system must be retained.

## **24. Fuel supply**

- E. Fuel lines from the fuel tank up to the injectors (fuel hoses, delivery pipe assembly, joints, clamps, fuel canister) may be replaced and must be in such a way that they are protected from crash damage.
- F. Quick connectors or dry break connectors may be used.
- G. Fuel vent lines may be replaced.
- H. Fuel filters may be added.

## **25. Exhaust system**

- E. Exhaust pipes, catalytic converters and silencers may be altered or replaced from those fitted to the homologated motorcycle. Catalytic converters may be removed.
- F. For safety reasons, the exposed edge(s) of the exhaust pipe(s) outlet(s) must be rounded to avoid any sharp edges.
- G. Wrapping of exhaust systems is allowed.
- H. The noise limit for Baggers will be 117dB/A measured at 3000RPM.(with a 3dB/ A tolerance after the race only).

## **26. Engine control system**

The engine control system (ECU)

- f. Original system as homologated, with or without software change.

- g. Approved aftermarket systems: Thundermax, S&S, Dyno Jet / PV, Techno Research and TTS.

Central unit (ECU) may be relocated.

The original sensors may not be replaced or modified. No additional sensors may be added to the machine for data collection.

No extra sensors may be added for control strategies except the throttle bodies, fuel pressure, oil pressure, lambda sensor and shift rod sensor.

No external module may add traction control strategies. The modules may only connect to the fuel injectors, ignition coils, lambda sensor, power supply and “piggyback the Throttle Position, Gear and RPM signals”. Lambda closed loop/ auto tuning is permitted.

Other additional electronic hardware equipment not on the original homologated motorcycle cannot be added with the exceptions noted below

- h. Resistors/load/electronic hardware may be added to replace the parts of the electrical system that have been removed (including lights, lambda sensors, etc.) to prevent ECU errors, also includes needed wiring for throttle bodies and turbo units.

Telemetry is not allowed.

No remote or wireless connection to the bike for any data exchange or setting is allowed whilst the engine is running, or the bike is moving.

Harness:

- i. The key/ignition lock may be relocated, replaced or removed.
- j. Cutting and removal of excess and unused wiring in the original wiring harness is allowed.

A lap timer may be fitted. GPS lap timers may be used. The lap timer may only be connected to the machine with a power and ground connection. Data collection from the machines sensors or ECU is allowed. Data collection by the lap timer by way of GPS and internal IMU is permitted.

Spark plugs may be replaced.

Battery is free.

## **27. Generator, alternator, electric starter**

- C. The stator/coil must be the originally fitted parts with no modification allowed.
- D. Motorcycles should self-start on the starting grid in neutral. Push-starting on the starting grid is not allowed, however start line Officials may push start the motorcycle if necessary (in gear).

## **28. Main frame and spare motorcycle**

- B. During the entire duration of the event, each rider may only use one (1) complete motorcycle.

## **29. Frame body and rear subframe**

- E. The main frame must be the originally manufactured and fitted part.
- F. Holes may be drilled on the frame to affix approved components (i.e. fairing brackets, saddlebag relocation, steering damper mounts, engine & chassis stabilizers etc.).
- G. All motorcycles must display a vehicle identification number punched on the frame body (a proper 'legal VIN')
- H. Crash protectors may be fitted to the frame using existing points or pressed into the ends of the wheel axles.

## **30. Suspension - General**

- B. Suspension may be modified but a similar system to the homologated must be used.

## **31. Front Suspension**

- E. The front fork in whole or part may be changed.
- F. The upper and lower fork clamps (triple clamp, fork bridges) and stem may be changed or modified.
- G. A steering damper may be added or replaced.
- H. The steering damper cannot act as a steering lock limiting device.

## **32. Swing-arm (Rear Fork)**

- F. Swing-arms may be replaced or modified.
- G. A Solid Protective Cover (sharkfin) shall be fixed to the swing-arm and must always cover the opening between the lower chain run, swing-arm and the rear wheel sprocket, irrespective of the position of the rear wheel.
- H. Rear wheel stand brackets may be added to the rear fork by welding or by bolts.
- I. Brackets must have rounded edges (with a large radius). Fastening screws must be recessed.

J. Swingarm spindle (pivot) may be modified or replaced.

### **33. Rear suspension unit**

C. Rear suspension unit may be changed but a similar system must be used (i.e. dual or mono).

D. Removable top shock mounts may be replaced. If replaced they must retain their homologated geometry.

### **34. Wheels**

G. Wheels may be replaced, and associated parts may be altered or replaced from those fitted to the homologated motorcycle.

H. Aftermarket Wheels Must Be Made From Aluminum Alloys.

I. The use of the following alloy materials for the wheels is not allowed: Beryllium ( $\geq 5\%$ ), Scandium ( $\geq 2\%$ ), Lithium ( $\geq 1\%$ ).

J. Bearings, seals, and axles may be altered or replaced from those fitted to the homologated motorcycle. The use of titanium and light alloys is forbidden for wheel spindles (axles).

K. Wheel balance weights may be discarded, changed or added to.

L. Aluminum or steel inflation valves are compulsory.

### **Wheel Sizes Front and Rear 17-19"**

### **35. Brakes**

Front brake master cylinder may be altered or replaced.

Front brake calipers may be altered or replaced.

Rear brake master cylinder may be altered or replaced.

Rear brake calipers may be altered or replaced.

Brake pads or shoes may be altered or replaced.

Brake hoses and brake couplings may be altered or replaced.

Hydraulic anti-knockback systems may be fitted to the brake lines/caliper.

Brake discs may be altered or replaced. Only Steel (max. carbon content 2.1wt.%) is allowed for brake discs. Alloys containing beryllium are not allowed to be used for brake calipers.

ABS systems must be removed or disabled if still on motorcycle.

### **36. Handlebars and hand controls**

- D. Handlebars, hand controls and cables may be altered or replaced from those fitted to the homologated motorcycle.
- E. Cable operated throttles (grip assembly) must be equipped with both an opening and a closing cable including when actuating a remote drive by wire grip/demand sensor.
- F. Motorcycles must be equipped with a functional ignition kill switch or button mounted on the right-hand handlebar (within reach of the hand while on the hand grips) that can stop a running engine. The button or switch must be RED.

### **37. Footrest and foot controls**

- B. Footrests, hangers/brackets and hardware may be replaced and relocated but the hangers/brackets must either be mounted to their original frame mounting points or another location that does not require the modification of the frame.

### **38. Fuel tank**

- E. The fuel tank must be the general shape and dimension of the originally fitted and homologated part.
- F. All fuel tanks must be completely filled with fire retardant material (i.e. fuel tank foam).
- G. Fuel tanks with tank breather pipes must be fitted with no-return valves that discharge into a catch tank with a minimum volume of 250 cc made of a suitable material.
- H. Material is free.

### **39. Fairing / Bodywork**

- H. The fairing, rear fender and body work must conform in principle to the homologated shape as originally produced by the manufacturer. Styling modifications are free. Front fender is free. Material is free. Headlights may be included even when considered external. All glass and plastic lenses should be covered by a clear vinyl or a vinyl replicating the look of the lens.
  - a. HarleyDavidson: must run a batwing fairing or Road Glide fairing. Either model fairing is acceptable regardless of the model HD motorcycle.
  - b. Indian Motorcycles: must replicate the originally fitted and homologated part
- I. The Windscreen Must Be Installed And Maybe Replaced.

- J. A lower catch/belly pan must be constructed to hold, in case of an engine breakdown, at least half of the total oil and engine coolant capacity used in the engine. Harley M8's ('17-'21) total engine has 5 qts (2.36L.) Harley Twin Cam ('99-'16) total engine has 4 qts (.89L).
- K. The saddlebags must conform in principle to the original shape as originally produced by the manufacturer. Styling Modifications are free.
- L. The inner side (next to the wheel) of the bag can be modified in shape but must remain stock size.
- M. Height may be altered a maximum of 2" in respect to the original mounting point on the subframe. Material is free.
- N. Saddlebag lids must conform in principle to the OEM dimensional spec and shape of originally fitted Touring model hard bags. Material is free.

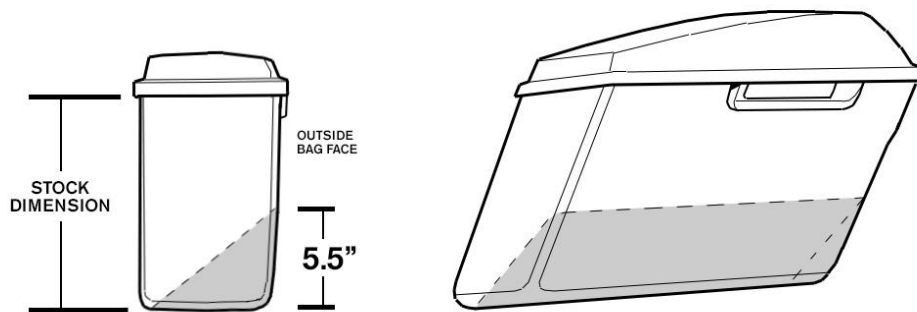

#### 40. Seat

- B. Seat may be altered or replaced.

#### 41. The following items **MAY BE** altered or replaced from those fitted to the homologated motorcycle.

- G. Any type of lubrication, brake or suspension fluid may be used.
- H. Gaskets, seals, and gasket material.
- I. Bearings (ball, roller, taper, plain, etc.) of any type or brand may be used.
- J. Fasteners (nuts, bolts, screws, etc.), but internal engine bolts must remain of standard homologated materials or materials of higher specific weight.
- K. Thread repair using inserts of different material such as helicoils and timeserts.
- L. External surface finishes and decals.

#### **42. The following items MAY BE removed**

- D. Instrument and instruments bracket and associated cables.
- E. Tachometer.
- F. Speedometer and associated wheel spacers.

#### **43. The Following Items MUST BE Removed**

- F. Rear-view mirrors.
- G. Horn.
- H. License plate bracket.
- I. Toolbox.
- J. Safety bars, center and side stand brackets welded to the main frame may be removed. If the side stand is not removed it must be held in the up position by a secondary device.

#### **44. Rider Requirements - Stunt GP Class**

- D. Stunt GP riders must have a novice road racing license.
- E. Rider must be signed off by any valid club Racing Organization.
- F. To achieve expert plates a Racer must race as an Amateur and acquire enough "points" to advance on to an Expert plate with a sanctioned race organization.

#### **45. Rider Gear Requirements - Stunt GP Class**

- F. **Helmet** – DOT full-face helmet (no flip up style). The helmet should meet SNELL or BSI certifications. The helmet should not be more than 5 years old, and it should be undamaged. Normal wear and tear from general use and transport are ok, but a helmet that has been crashed in or that has been visibly damaged will not pass tech.
- G. **Suit** – 1 or 2-piece. If it is 2-piece, it must affix together via a zipper between the jacket and the pants.
- H. **Back Protector** – An aftermarket back protector is highly recommended, back protector must be a CE-approved foam insert at the minimum.
- I. **Gloves** – Gauntlet-style glove that provides full coverage over your wrists and overlaps your leathers. Gloves should be in good condition and without holes or damage.
- J. **Boots** – Provide full ankle coverage. They may be worn under the legs of your pants only if your Race Suit pant legs are designed for this. Otherwise, your boots must fully overlap the pant legs on your suit.

For more information contact the BAGGER RACING LEAGUE.





# PRO STOCK BAGGER

## PRO STOCK BAGGER GP TECHNICAL SPECIFICATIONS

The following rules are intended to give freedom to modify or replace some parts in the interest of safety, research and development and improved competition between various motorcycle concepts.

### **EVERYTHING THAT IS NOT AUTHORIZED AND PRESCRIBED IN THIS RULE IS STRICTLY FORBIDDEN**

#### **1. Motorcycle specifications**

All Years	Harley-Davidson FL Touring
All Years	Indian Bagger or Touring

#### **2. Engine configurations and displacement capacities**

##### **Harley-Davidson Motorcycles:**

- G. Originally equipped air-cooled pushrod V-Twin engines, maximum displacement of 131ci. normally aspirated.
- H. S&S or Jim's air-cooled pushrod Twin Cam engines w/MSO are acceptable up to 131ci. normally aspirated.
- I. Forced induction air-cooled pushrod V-Twin engines allowed with maximum displacement of 107ci.

##### **Indian Motorcycles:**

- G. Originally equipped water-cooled V-Twin Engine, maximum displacement of 112ci. normally aspirated.
- H. Originally equipped air-cooled pushrod V-Twin Engine, maximum displacement of 131ci. normally aspirated.
- I. Forced induction air-cooled pushrod V-Twin engines allowed with maximum displacement of 111ci.

#### **3. Balancing various motorcycle concepts**

In order to equalize the performance of motorcycles used in the BRL, a system of performance enhancements or restrictions have been developed

(such as minimum weight, air restrictor or REV limit may be applied according to their respective racing performances). The decision to apply a balancing system to a motorcycle will be taken by the Bagger Racing League officials based on decisions made by the BRL officials at any time deemed necessary to ensure fair competition.

#### **4. Minimum weight**

**Harley Davidson: Minimum weight - 500 lbs.**

**Indian Air Cooled Pushrod: Minimum weight - 500 lbs.**

**Indian Challenger: Minimum weight - 635 lbs**

At any time of the event, the weight of the whole motorcycle (including the tank and its contents) must not be lower than the minimum weight.

There is no tolerance on the minimum weight of the motorcycle.

During the final technical inspection at the end of the race, the selected motorcycles will be weighed in the condition they finished the race, and the established weight limit must be met in this condition. Nothing may be added to the motorcycle. This includes all fluids.

During the practice and qualifying sessions, riders may be asked to submit their motorcycle to a weight control. In all cases, the rider must comply with this request.

The use of ballast is allowed to stay over the minimum weight limit and may be required due to the handicap system. The use of ballast and weight handicap must be declared to the Technical Director at the preliminary checks.

#### **5. Numbers and number plates**

The background colors and figures (numbers) for Baggers may be any color but must be strongly contrasting.

#### **6. Fuel**

B. All competitors must use TBD. Fuel Specification T4.

#### **7. Tires**

C. All machines must be fitted with TBD. Specification (TBD)

## 8. Engine

### 9. Fuel system

- G. The original equipped fuel system must be used.
- H. Air funnels, throttle bodies and airbox may be altered or replaced.
- I. Air and air/fuel mixture must go to the combustion chamber exclusive through the throttle bodies/ Intake manifolds.

### 10. Cylinder Head

**Air Cooled Pushrod Engines:** Cylinder heads may be altered or replaced.

**Water cooled engines:** Cylinder heads must be the originally fitted part with the following modifications allowed:

The cylinder head must begin as a finished production part using originally equipped materials and castings.

Porting and polishing of the cylinder head normally associated with individual tuning such as gas flowing of the cylinder head, including the combustion chamber is allowed. Epoxy may be used to shape the ports.

The throttle body intake insulators may be modified.

The compression ratio is free.

The combustion chamber may be modified.

Valves may be modified.

Valve seats can be modified or replaced for repair.

Valve guides may be modified.

Valves must remain in the homologated location and at the same angle.

Rocker arms (if any) may be modified.

The exhaust air bleed system may be blocked.

Valve springs may be modified.

## **11. Camshaft**

C. Camshafts may be altered or replaced.

## **12. Cam sprockets or cam gears**

- E. Camshaft sprockets, pulleys or gears may be altered or replaced to allow degreeing of the camshafts.
- F. The cam chain or cam belt tensioning device(s) can be modified or changed.

## **13. Cylinders**

- G. Normally aspirated air-cooled pushrod engines may increase the bore to a maximum total displacement of 131ci.
- H. Normally aspirated water-cooled engines are limited to 112ci.
- I. Forced induction engines: Harley Davidson air-cooled 107 ci./ Indian air-cooled 111 ci.

## **14. Pistons, rings, pins and clips.**

- E. Air cooled pushrod V-Twin engines: May be modified.
- F. Water cooled engine: must be factory or factory option homologated parts.

## **15. Connecting rods**

- E. Connecting rod may be altered or replaced.
- F. Connecting rod bolts are free but must be of the same weight or heavier, and of the same material as the original bolt or of higher specific weight material.

## **16. Crankshaft**

Only the following modifications can be made to the crankshaft:

- I. Stroke may be modified on air cooled pushrod V-Twin engines. Water cooled to remain the same as the originally fitted and homologated part.
- J. Bearing surfaces may be polished.
- K. Surface treatments may be applied to the crankshaft.
- L. Balancing is allowed.

## **17. Crankcase / Gearbox housing**

- K. Crankcases must be the originally fitted part with only the following modifications allowed. If the crankcases have an integral cylinder, then the top face of the cylinder may be ground to adjust deck height. Oil Spray nozzles may be

modified. Air Cooled Pushrod Engines: may modify case for camshaft clearance, crank balance shaft removal and tapered crankshaft bearing upgrades.

- L. No other modifications are allowed (including painting & polishing).
- M. Only the original or an approved sump Oil-pan (sump) and oil pick up can be used.
- N. Oil breather cover must remain as original, but the internal breather/damper plate can be modified or replaced.
- O. Oil tank breathers are acceptable and may run through an external catch can but all exits are advised to be routed to the intake system.

### **18. Lateral covers and protection**

- G. Lateral (side) covers may be altered, modified or replaced (excluding pump covers). If altered or modified, the cover must have at least the same resistance to impact as the original one. If replaced, the cover must be made in material of same or higher specific weight and the total weight of the cover must not be less than the original one.
- H. All lateral covers/engine cases containing oil, and which could be in contact with the ground during a crash, must be protected by a second cover made from metal such as aluminum alloy, stainless steel, steel or titanium.
- I. All drain and fill plugs must be lock wired (safety wired). The use of clips is not permitted. External oil filter(s), screws and bolts that enter an oil cavity must be safety wired (i.e. on crankcases) or the oil filter may optionally have a secondary retention mechanism.

### **19. Transmission / Gearbox**

- G. The layout of the transmission shafts must be the same as on the homologated motorcycle.
- H. The gear design and material are free.
- I. Final drive belt systems may be converted to chain type systems.

### **20. Clutch**

- C. Aftermarket or modified clutches are permitted (including plates/springs/baskets etc.).

### **21. Oil pumps, cam plates and oil lines**

- E. The oil pump and camplate may be modified or replaced.

- F. Oil lines may be modified or replaced. Oil lines containing positive pressure, if replaced, must be of braided reinforced construction with swaged or threaded connectors.

## **22. Cooling System**

- G. The only liquid engine coolants permitted is water.
- H. Additional radiators or oil coolers may be added.
- I. The original oil/water heat exchanger may be modified, replaced or removed.

## **23. Airbox**

- G. The airbox may be modified or replaced.
- H. Airboxes should be designed to retain oil from the crankcases in the event of engine failure or tip-over.
- I. Where breather or overflow pipes are fitted, they must discharge via existing outlets. Catch cans may be used but the original closed system must be retained.

## **24. Fuel supply**

- I. Fuel lines from the fuel tank up to the injectors (fuel hoses, delivery pipe assembly, joints, clamps, fuel canister) may be replaced and must be in such a way that they are protected from crash damage.
- J. Quick connectors or dry break connectors may be used.
- K. Fuel vent lines may be replaced.
- L. Fuel filters may be added.

## **25. Exhaust system**

- I. Exhaust pipes, catalytic converters and silencers may be altered or replaced from those fitted to the homologated motorcycle. Catalytic converters may be removed.
- J. For safety reasons, the exposed edge(s) of the exhaust pipe(s) outlet(s) must be rounded to avoid any sharp edges.
- K. Wrapping of exhaust systems is allowed.
- L. The noise limit for Baggers will be 117dB/A measured at 3000RPM.(with a 3dB/ A tolerance after the race only).

## **26. Engine control system**

The engine control system (ECU)

- k. Original system as homologated, with or without software change.
- l. Approved aftermarket systems: Thundermax, S&S, Dyno Jet / PV, Techno Research and TTS.

Central unit (ECU) may be relocated.

The original sensors may not be replaced or modified. No additional sensors may be added to the machine for data collection.

No extra sensors may be added for control strategies except the throttle bodies, fuel pressure, oil pressure, lambda sensor and shift rod sensor.

No external module may add traction control strategies. The modules may only connect to the fuel injectors, ignition coils, lambda sensor, power supply and “piggyback the Throttle Position, Gear and RPM signals”. Lambda closed loop/ auto tuning is permitted.

Other additional electronic hardware equipment not on the original homologated motorcycle cannot be added with the exceptions noted below

- m. Resistors/load/electronic hardware may be added to replace the parts of the electrical system that have been removed (including lights, lambda sensors, etc.) to prevent ECU errors, also includes needed wiring for throttle bodies and turbo units.

Telemetry is not allowed.

No remote or wireless connection to the bike for any data exchange or setting is allowed whilst the engine is running, or the bike is moving.

Harness:

- n. The key/ignition lock may be relocated, replaced or removed.
- o. Cutting and removal of excess and unused wiring in the original wiring harness is allowed.

A lap timer may be fitted. GPS lap timers may be used. The lap timer may only be connected to the machine with a power and ground connection. Data collection from the machines sensors or ECU is allowed. Data collection by the lap timer by way of GPS and internal IMU is permitted.

Spark plugs may be replaced.

Battery is free.



## **27. Generator, alternator, electric starter**

- E. The stator/coil must be the originally fitted parts with no modification allowed.
- F. Motorcycles should self-start on the starting grid in neutral. Push-starting on the starting grid is not allowed, however start line Officials may push start the motorcycle if necessary (in gear).

## **28. Main frame and spare motorcycle**

- C. During the entire duration of the event, each rider may only use one (1) complete motorcycle.

## **29. Frame body and rear subframe**

- I. The main frame must be the originally manufactured and fitted part.
- J. Holes may be drilled on the frame to affix approved components (i.e. fairing brackets, saddlebag relocation, steering damper mounts, engine & chassis stabilizers etc.).
- K. All motorcycles must display a vehicle identification number punched on the frame body (a proper 'legal VIN')
- L. Crash protectors may be fitted to the frame using existing points or pressed into the ends of the wheel axles.

## **30. Suspension - General**

- C. Suspension may be modified but a similar system to the homologated must be used.

## **31. Front Suspension**

- I. The front fork in whole or part may be changed.
- J. The upper and lower fork clamps (triple clamp, fork bridges) and stem may be changed or modified.
- K. A steering damper may be added or replaced.
- L. The steering damper cannot act as a steering lock limiting device.

## **32. Swing-arm (Rear Fork)**

- K. Swing-arms may be replaced or modified.
- L. A Solid Protective Cover (sharkfin) shall be fixed to the swing-arm and must always cover the opening between the lower chain run, swing-arm and the rear wheel sprocket, irrespective of the position of the rear wheel.
- M. Rear wheel stand brackets may be added to the rear fork by welding or by bolts.

- N. Brackets must have rounded edges (with a large radius). Fastening screws must be recessed.
- O. Swingarm spindle (pivot) may be modified or replaced.

### **33. Rear suspension unit**

- E. Rear suspension unit may be changed but a similar system must be used (i.e. dual or mono).
- F. Removable top shock mounts may be replaced. If replaced they must retain their homologated geometry.

### **34. Wheels**

- M. Wheels may be replaced, and associated parts may be altered or replaced from those fitted to the homologated motorcycle.
- N. Aftermarket Wheels Must Be Made From Aluminum Alloys.
- O. The use of the following alloy materials for the wheels is not allowed: Beryllium ( $\geq 5\%$ ), Scandium ( $\geq 2\%$ ), Lithium ( $\geq 1\%$ ).
- P. Bearings, seals, and axles may be altered or replaced from those fitted to the homologated motorcycle. The use of titanium and light alloys is forbidden for wheel spindles (axles).
- Q. Wheel balance weights may be discarded, changed or added to.
- R. Aluminum or steel inflation valves are compulsory.

#### **Wheel Sizes Front and Rear 17-19"**

### **35. Brakes**

Front brake master cylinder may be altered or replaced.

Front brake calipers may be altered or replaced.

Rear brake master cylinder may be altered or replaced.

Rear brake calipers may be altered or replaced.

Brake pads or shoes may be altered or replaced.

Brake hoses and brake couplings may be altered or replaced.

Hydraulic anti-knockback systems may be fitted to the brake lines/caliper.

Brake discs may be altered or replaced. Only Steel (max. carbon content 2.1wt.%) is allowed for brake discs. Alloys containing beryllium are not allowed to be used for brake calipers.

ABS systems must be removed or disabled if still on motorcycle.

### **36. Handlebars and hand controls**

- G. Handlebars, hand controls and cables may be altered or replaced from those fitted to the homologated motorcycle.
- H. Cable operated throttles (grip assembly) must be equipped with both an opening and a closing cable including when actuating a remote drive by wire grip/demand sensor.
- I. Motorcycles must be equipped with a functional ignition kill switch or button mounted on the right-hand handlebar (within reach of the hand while on the hand grips) that can stop a running engine. The button or switch must be RED.

### **37. Footrest and foot controls**

- C. Footrests, hangers/brackets and hardware may be replaced and relocated but the hangers/brackets must either be mounted to their original frame mounting points or another location that does not require the modification of the frame.

### **38. Fuel tank**

- I. The fuel tank must be the general shape and dimension of the originally fitted and homologated part.
- J. All fuel tanks must be completely filled with fire retardant material (i.e. fuel tank foam).
- K. Fuel tanks with tank breather pipes must be fitted with no-return valves that discharge into a catch tank with a minimum volume of 250 cc made of a suitable material.
- L. Material is free.

### **39. Fairing / Bodywork**

- O. The fairing, rear fender and body work must conform in principle to the homologated shape as originally produced by the manufacturer. Styling modifications are free. Front fender is free. Material is free. Headlights may be included even when considered external. All glass and plastic lenses should be covered by a clear vinyl or a vinyl replicating the look of the lens.
  - a. HarleyDavidson: must run a batwing fairing or Road Glide fairing. Either model fairing is acceptable regardless of the model HD motorcycle.

- b. Indian Motorcycles: must replicate the originally fitted and homologated part
- P. The Windscreen Must Be Installed And Maybe Replaced.
- Q. A lower catch/belly pan must be constructed to hold, in case of an engine breakdown, at least half of the total oil and engine coolant capacity used in the engine. Harley M8's ('17-'21) total engine has 5 qts (2.36L.) Harley Twin Cam ('99-'16) total engine has 4 qts (.89L).
- R. The saddlebags must conform in principle to the original shape as originally produced by the manufacturer. Styling Modifications are free.
- S. The inner side (next to the wheel) of the bag can be modified in shape but must remain stock size.
- T. Height may be altered a maximum of 2" in respect to the original mounting point on the subframe. Material is free.
- U. Saddlebag lids must conform in principle to the OEM dimensional spec and shape of originally fitted Touring model hard bags. Material is free.

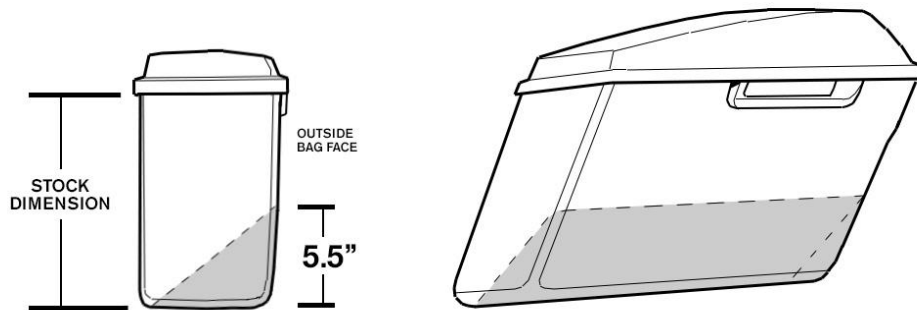

#### 40. Seat

- C. Seat may be altered or replaced.

#### 41. The following items **MAY BE** altered or replaced from those fitted to the homologated motorcycle.

- M. Any type of lubrication, brake or suspension fluid may be used.
- N. Gaskets, seals, and gasket material.
- O. Bearings (ball, roller, taper, plain, etc.) of any type or brand may be used.

- P. Fasteners (nuts, bolts, screws, etc.), but internal engine bolts must remain of standard homologated materials or materials of higher specific weight.
- Q. Thread repair using inserts of different material such as helicoils and timeserts.
- R. External surface finishes and decals.

#### **42. The following items MAY BE removed**

- G. Instrument and instruments bracket and associated cables.
- H. Tachometer.
- I. Speedometer and associated wheel spacers.

#### **43. The Following Items MUST BE Removed**

- K. Rear-view mirrors.
- L. Horn.
- M. License plate bracket.
- N. Toolbox.
- O. Safety bars, center and side stand brackets welded to the main frame may be removed. If the side stand is not removed it must be held in the up position by a secondary device.

#### **44. Rider Requirements - Pro Stock Bagger GP Class**

- G. Pro Stock Bagger GP riders must have a novice road racing license.
- H. Rider must be signed off by any valid club Racing Organization.
- I. To achieve expert plates a Racer must race as an Amateur and acquire enough "points" to advance on to an Expert plate with a sanctioned race organization.

#### **45. Rider Gear Requirements - Pro Stock Bagger GP Class**

- K. **Helmet** – DOT full-face helmet (no flip up style). The helmet should meet SNELL or BSI certifications. The helmet should not be more than 5 years old, and it should be undamaged. Normal wear and tear from general use and transport are ok, but a helmet that has been crashed in or that has been visibly damaged will not pass tech.
- L. **Suit** – 1 or 2-piece. If it is 2-piece, it must affix together via a zipper between the jacket and the pants.
- M. **Back Protector** – An aftermarket back protector is highly recommended, back protector must be a CE-approved foam insert at the minimum.
- N. **Gloves** – Gauntlet-style glove that provides full coverage over your wrists and overlaps your leathers. Gloves should be in good condition and without holes or damage.

- O. **Boots** – Provide full ankle coverage. They may be worn under the legs of your pants only if your Race Suit pant legs are designed for this. Otherwise, your boots must fully overlap the pant legs on your suit.

For more information contact the BAGGER RACING LEAGUE.

# **BIG TWIN GP**

## **BIG TWIN GP TECHNICAL SPECIFICATIONS**

The following rules are intended to give freedom to modify or replace some parts in the interest of safety, research and development and improved competition between various motorcycle concepts.

### **EVERYTHING THAT IS NOT AUTHORIZED AND PRESCRIBED IN THIS RULE IS STRICTLY FORBIDDEN**

#### **1. Motorcycle specifications**

All Years                      Harley-Davidson Non Touring Air Cooled Models

All Years                      Indian Non Touring Air Cooled Models

#### **2. Engine configurations and displacement capacities**

##### **Harley-Davidson Motorcycles:**

- J. Originally equipped air-cooled pushrod V-Twin engines, maximum displacement of 131ci. normally aspirated.
- K. S&S or Jim's air-cooled pushrod Twin Cam engines w/MSO are acceptable up to 131ci. normally aspirated.
- L. Forced induction air-cooled pushrod V-Twin engines allowed with maximum displacement of 107ci.

##### **Indian Motorcycles:**

- J. Originally equipped air-cooled pushrod V-Twin Engine, maximum displacement of 131ci. normally aspirated.
- K. Forced induction air-cooled pushrod V-Twin engines allowed with maximum displacement of 111ci.

#### **3. Balancing various motorcycle concepts**

In order to equalize the performance of motorcycles used in the BRL, a system of performance enhancements or restrictions have been developed

#### **4. No Minimum weight**

#### **5. Numbers and number plates**

The background colors and figures (numbers) for Baggers may be any color but must be strongly contrasting.

#### **6. Fuel**

C. All competitors must use TBD. Fuel Specification T4.

#### **7. Tires**

D. All machines must be fitted with TBD. Specification (TBD)

#### **8. Engine Section**

##### **9. Fuel system**

- J. The original equipped fuel system must be used.
- K. Air funnels, throttle bodies and airbox may be altered or replaced.
- L. Air and air/fuel mixture must go to the combustion chamber exclusive through the throttle bodies/ Intake manifolds.

##### **10. Cylinder Head**

**Air Cooled Pushrod Engines:** Cylinder heads may be altered or replaced.

**Water cooled engines:** Cylinder heads must be the originally fitted part with the following modifications allowed:

The cylinder head must begin as a finished production part using originally equipped materials and castings.

Porting and polishing of the cylinder head normally associated with individual tuning such as gas flowing of the cylinder head, including the combustion chamber is allowed. Epoxy may be used to shape the ports.

The throttle body intake insulators may be modified.

The compression ratio is free.



The combustion chamber may be modified.

Valves may be modified.

Valve seats can be modified or replaced for repair.

Valve guides may be modified.

Valves must remain in the homologated location and at the same angle.

Rocker arms (if any) may be modified.

The exhaust air bleed system may be blocked.

Valve springs may be modified.

### **11. Camshaft**

D. Camshafts may be altered or replaced.

### **12. Cam sprockets or cam gears**

G. Camshaft sprockets, pulleys or gears may be altered or replaced to allow degreasing of the camshafts.

H. The cam chain or cam belt tensioning device(s) can be modified or changed.

### **13. Cylinders**

J. Normally aspirated air-cooled pushrod engines may increase the bore to a maximum total displacement of 131ci.

K. Normally aspirated water-cooled engines are limited to 112ci.

L. Forced induction engines: Harley Davidson air-cooled 107 ci./ Indian air-cooled 111 ci.

### **14. Pistons, rings, pins and clips.**

G. Air cooled pushrod V-Twin engines: May be modified.

H. Water cooled engine: must be factory or factory option homologated parts.

### **15. Connecting rods**

G. Connecting rod may be altered or replaced.

H. Connecting rod bolts are free but must be of the same weight or heavier, and of the same material as the original bolt or of higher specific weight material.

## **16. Crankshaft**

Only the following modifications can be made to the crankshaft:

- M. Stroke may be modified on air cooled pushrod V-Twin engines. Water cooled to remain the same as the originally fitted and homologated part.
- N. Bearing surfaces may be polished.
- O. Surface treatments may be applied to the crankshaft.
- P. Balancing is allowed.

## **17. Crankcase / Gearbox housing**

- P. Crankcases must be the originally fitted part with only the following modifications allowed. If the crankcases have an integral cylinder, then the top face of the cylinder may be ground to adjust deck height. Oil Spray nozzles may be modified. Air Cooled Pushrod Engines: may modify case for camshaft clearance, crank balance shaft removal and tapered crankshaft bearing upgrades.
- Q. No other modifications are allowed (including painting & polishing).
- R. Only the original or an approved sump Oil-pan (sump) and oil pick up can be used.
- S. Oil breather cover must remain as original, but the internal breather/damper plate can be modified or replaced.
- T. Oil tank breathers are acceptable and may run through an external catch can but all exits are advised to be routed to the intake system.

## **18. Lateral covers and protection**

- J. Lateral (side) covers may be altered, modified or replaced (excluding pump covers). If altered or modified, the cover must have at least the same resistance to impact as the original one. If replaced, the cover must be made in material of same or higher specific weight and the total weight of the cover must not be less than the original one.
- K. All lateral covers/engine cases containing oil, and which could be in contact with the ground during a crash, must be protected by a second cover made from metal such as aluminum alloy, stainless steel, steel or titanium.
- L. All drain and fill plugs must be lock wired (safety wired). The use of clips is not permitted. External oil filter(s), screws and bolts that enter an oil cavity must be safety wired (i.e. on crankcases) or the oil filter may optionally have a secondary retention mechanism.

## **19. Transmission / Gearbox**

- J. The layout of the transmission shafts must be the same as on the homologated motorcycle.
- K. The gear design and material are free.
- L. Final drive belt systems may be converted to chain type systems.

## **20. Clutch**

- D. Aftermarket or modified clutches are permitted (including plates/springs/baskets etc.).

## **21. Oil pumps, cam plates and oil lines**

- G. The oil pump and camplate may be modified or replaced.
- H. Oil lines may be modified or replaced. Oil lines containing positive pressure, if replaced, must be of braided reinforced construction with swaged or threaded connectors.

## **22. Cooling System**

- J. The only liquid engine coolants permitted is water.
- K. Additional radiators or oil coolers may be added.
- L. The original oil/water heat exchanger may be modified, replaced or removed.

## **23. Airbox**

- J. The airbox may be modified or replaced.
- K. Airboxes should be designed to retain oil from the crankcases in the event of engine failure or tip-over.
- L. Where breather or overflow pipes are fitted, they must discharge via existing outlets. Catch cans may be used but the original closed system must be retained.

## **24. Fuel supply**

- M. Fuel lines from the fuel tank up to the injectors (fuel hoses, delivery pipe assembly, joints, clamps, fuel canister) may be replaced and must be in such a way that they are protected from crash damage.
- N. Quick connectors or dry break connectors may be used.
- O. Fuel vent lines may be replaced.
- P. Fuel filters may be added.

## 25. Exhaust system

- M. Exhaust pipes, catalytic converters and silencers may be altered or replaced from those fitted to the homologated motorcycle. Catalytic converters may be removed.
- N. For safety reasons, the exposed edge(s) of the exhaust pipe(s) outlet(s) must be rounded to avoid any sharp edges.
- O. Wrapping of exhaust systems is allowed.
- P. The noise limit for Baggers will be 117dB/A measured at 3000RPM.(with a 3dB/ A tolerance after the race only).

## 26. Engine control system

The engine control system (ECU)

- p. Original system as homologated, with or without software change.
- q. Approved aftermarket systems: Thundermax, S&S, Dyno Jet / PV, Techno Research and TTS.

Central unit (ECU) may be relocated.

The original sensors may not be replaced or modified. No additional sensors may be added to the machine for data collection.

No extra sensors may be added for control strategies except the throttle bodies, fuel pressure, oil pressure, lambda sensor and shift rod sensor.

No external module may add traction control strategies. The modules may only connect to the fuel injectors, ignition coils, lambda sensor, power supply and "piggyback the Throttle Position, Gear and RPM signals". Lambda closed loop/ auto tuning is permitted.

Other additional electronic hardware equipment not on the original homologated motorcycle cannot be added with the exceptions noted below

- r. Resistors/load/electronic hardware may be added to replace the parts of the electrical system that have been removed (including lights, lambda sensors, etc.) to prevent ECU errors, also includes needed wiring for throttle bodies and turbo units.

Telemetry is not allowed.

No remote or wireless connection to the bike for any data exchange or setting is allowed whilst the engine is running, or the bike is moving.

Harness:

- s. The key/ignition lock may be relocated, replaced or removed.
- t. Cutting and removal of excess and unused wiring in the original wiring harness is allowed.

A lap timer may be fitted. GPS lap timers may be used. The lap timer may only be connected to the machine with a power and ground connection. Data collection from the machines sensors or ECU is allowed. Data collection by the lap timer by way of GPS and internal IMU is permitted.

Spark plugs may be replaced.

Battery is free.

## **27. Generator, alternator, electric starter**

- G. The stator/coil must be the originally fitted parts with no modification allowed.
- H. Motorcycles should self-start on the starting grid in neutral. Push-starting on the starting grid is not allowed, however start line Officials may push start the motorcycle if necessary (in gear).

## **28. Main frame and spare motorcycle**

- D. During the entire duration of the event, each rider may only use one (1) complete motorcycle.

## **29. Frame body and rear subframe**

- M. The main frame must be the originally manufactured and fitted part.
- N. Holes may be drilled on the frame to affix approved components (i.e. fairing brackets, saddlebag relocation, steering damper mounts, engine & chassis stabilizers etc.).
- O. All motorcycles must display a vehicle identification number punched on the frame body (a proper 'legal VIN')
- P. Crash protectors may be fitted to the frame using existing points or pressed into the ends of the wheel axles.

## **30. Suspension - General**

- D. Suspension may be modified but a similar system to the homologated must be used.

## **31. Front Suspension**

- M. The front fork in whole or part may be changed.
- N. The upper and lower fork clamps (triple clamp, fork bridges) and stem may be changed or modified.
- O. A steering damper may be added or replaced.
- P. The steering damper cannot act as a steering lock limiting device.

### **32. Swing-arm (Rear Fork)**

- P. Swing-arms may be replaced or modified.
- Q. A Solid Protective Cover (sharkfin) shall be fixed to the swing-arm and must always cover the opening between the lower chain run, swing-arm and the rear wheel sprocket, irrespective of the position of the rear wheel.
- R. Rear wheel stand brackets may be added to the rear fork by welding or by bolts.
- S. Brackets must have rounded edges (with a large radius). Fastening screws must be recessed.
- T. Swingarm spindle (pivot) may be modified or replaced.

### **33. Rear suspension unit**

- G. Rear suspension unit may be changed but a similar system must be used (i.e. dual or mono).
- H. Removable top shock mounts may be replaced. If replaced they must retain their homologated geometry.

### **34. Wheels**

- S. Wheels may be replaced, and associated parts may be altered or replaced from those fitted to the homologated motorcycle.
- T. Aftermarket Wheels Must Be Made From Aluminum Alloys.
- U. The use of the following alloy materials for the wheels is not allowed: Beryllium ( $\geq 5\%$ ), Scandium ( $\geq 2\%$ ), Lithium ( $\geq 1\%$ ).
- V. Bearings, seals, and axles may be altered or replaced from those fitted to the homologated motorcycle. The use of titanium and light alloys is forbidden for wheel spindles (axles).
- W. Wheel balance weights may be discarded, changed or added to.
- X. Aluminum or steel inflation valves are compulsory.

### **Wheel Sizes Front and Rear 17-19"**

### **35. Brakes**

Front brake master cylinder may be altered or replaced.

Front brake calipers may be altered or replaced.

Rear brake master cylinder may be altered or replaced.

Rear brake calipers may be altered or replaced.

Brake pads or shoes may be altered or replaced.

Brake hoses and brake couplings may be altered or replaced.

Hydraulic anti-knockback systems may be fitted to the brake lines/caliper.

Brake discs may be altered or replaced. Only Steel (max. carbon content 2.1wt.%) is allowed for brake discs. Alloys containing beryllium are not allowed to be used for brake calipers.

ABS systems must be removed or disabled if still on motorcycle.

### **36. Handlebars and hand controls**

- J. Handlebars, hand controls and cables may be altered or replaced from those fitted to the homologated motorcycle.
- K. Cable operated throttles (grip assembly) must be equipped with both an opening and a closing cable including when actuating a remote drive by wire grip/demand sensor.
- L. Motorcycles must be equipped with a functional ignition kill switch or button mounted on the right-hand handlebar (within reach of the hand while on the hand grips) that can stop a running engine. The button or switch must be RED.

### **37. Footrest and foot controls**

- D. Footrests, hangers/brackets and hardware may be replaced and relocated but the hangers/brackets must either be mounted to their original frame mounting points or another location that does not require the modification of the frame.

### **38. Fuel tank**

- M. The fuel tank must be the general shape and dimension of the originally fitted and homologated part.
- N. All fuel tanks must be completely filled with fire retardant material (i.e. fuel tank foam).
- O. Fuel tanks with tank breather pipes must be fitted with no-return valves that discharge into a catch tank with a minimum volume of 250 cc made of a suitable material.

P. Material is free.

### **39. Seat**

D. Seat may be altered or replaced.

### **40. The following items MAY BE altered or replaced from those fitted to the homologated motorcycle.**

- S. Any type of lubrication, brake or suspension fluid may be used.
- T. Gaskets, seals, and gasket material.
- U. Bearings (ball, roller, taper, plain, etc.) of any type or brand may be used.
- V. Fasteners (nuts, bolts, screws, etc.), but internal engine bolts must remain of standard homologated materials or materials of higher specific weight.
- W. Thread repair using inserts of different material such as helicoils and timeserts.
- X. External surface finishes and decals.

### **41. The following items MAY BE removed**

- J. Instrument and instruments bracket and associated cables.
- K. Tachometer.
- L. Speedometer and associated wheel spacers.

### **42. The Following Items MUST BE Removed**

- P. Rear-view mirrors.
- Q. Horn.
- R. License plate bracket.
- S. Toolbox.
- T. Safety bars, center and side stand brackets welded to the main frame may be removed. If the side stand is not removed it must be held in the up position by a secondary device.

### **43. Rider Requirements - Pro Stock Bagger GP Class**

- J. Pro Stock Bagger GP riders must have a novice road racing license.
- K. Rider must be signed off by any valid club Racing Organization.
- L. To achieve expert plates a Racer must race as an Amateur and acquire enough "points" to advance on to an Expert plate with a sanctioned race organization.

### **44. Rider Gear Requirements - Pro Stock Bagger GP Class**



- P. **Helmet** – DOT full-face helmet (no flip up style). The helmet should meet SNELL or BSI certifications. The helmet should not be more than 5 years old, and it should be undamaged. Normal wear and tear from general use and transport are ok, but a helmet that has been crashed in or that has been visibly damaged will not pass tech.
- Q. **Suit** – 1 or 2-piece. If it is 2-piece, it must affix together via a zipper between the jacket and the pants.
- R. **Back Protector** – An aftermarket back protector is highly recommended, back protector must be a CE-approved foam insert at the minimum.
- S. **Gloves** – Gauntlet-style glove that provides full coverage over your wrists and overlaps your leathers. Gloves should be in good condition and without holes or damage.
- T. **Boots** – Provide full ankle coverage. They may be worn under the legs of your pants only if your Race Suit pant legs are designed for this. Otherwise, your boots must fully overlap the pant legs on your suit.

For more information contact the BAGGER RACING LEAGUE.

## **HOOLIGAN GP**

### Eligibility

- a. Riders that have finished in the Top 10 in the 2020 year end standings in any AFT class is NOT permitted.

### Frames

- a. Stock Production Street Bike Frames
  1. Stock production motorcycles must have originated with a 649cc or larger displacement twin, triple, or multi cylinder engine. Model year 1986-Newer.
  2. No geometry changes allowed that are not bolt-on.
  3. No fabrication allowed to change neck angle, no moving stock swingarm pivot location on frame, or changing stock upper shock mount location(s), unless it is a bolt-on modification.
  4. Aftermarket swing arms are allowed.
- b. Cracked or broken frames are prohibited.
- c. Kickstands must be removed or secured.

### Brakes

- a. No front brakes are allowed for oval events.
- b. Front brakes are allowed only for specified TT events.

### Tires

- a. 19" Flat Track racing tires or 17" wet/rain racing tires only.
- b. Tires from any manufacturer are permitted.
- c. No knobbies, street, dual sport or other tire types allowed.

### Engines

- a. Stock, production motorcycle must have originated with a 649cc or larger displacement twin, triple, or multi cylinder engine. Engine modifications are unlimited.

### Exhaust System

- a. Exhaust pipes and mufflers must be used and be securely attached together and bolted to the frame. Mufflers must have sound absorption mechanisms or packed Baffling.
- b. The discharge end of the exhaust pipe may not extend beyond the rear edge of the rear tire. For safety reasons, the exposed edge(s) of the exhaust pipe outlet(s) must be rounded to eliminate any sharp edges.
- c. The inside of the exhaust discharge end must be a maximum of five inches from the outside edge of the tire or frame in order to prevent another rider's wheel or leg from becoming trapped.

#### Coolant/Fluid Containment

- a. Coolant may be propylene glycol based. It must be nontoxic and water soluble. Ethylene glycol is not an acceptable coolant.
- b. Engines with fluids leaking from any of the breathers will not be allowed onto the race track.

#### Handlebars and Controls

- a. Cracked or broken handlebars are prohibited.
- b. Control levers must have minimum 0.25-inch diameter ball ends.
- c. Motorcycles must be equipped with a functional ignition cut-off switch or button, mounted on the handlebar and within reach of the rider's hand when placed on the grip. Momentary-off style switches are recommended and preferred.
- d. Motorcycles must have a self-closing throttle mechanism.
- e. All handlebar ends must present no cutting hazard.
- f. All levers, pegs and other protruding parts must be rounded or taped for safety.

#### Lights

- a. Lights and turn indicators should be removed if possible.
- b. All lights not removed must be completely covered with tape so any and all glass/plastic is retained in the event of an impact. Clear tape is acceptable.

#### Number Plates

- a. Motorcycles should be equipped with 3 legible number plates; 1 on the front, and 1 on each side, but is not mandatory.
- b. 10" x 12" GNHC series (blue background and white numbers) plates are the recommended color scheme, but not mandatory.
- c. Variations from the above guidelines may affect how well you are scored at the event.

### **Rider Requirements - Hooligan GP Class**

- M. Hooligan GP riders must have a novice road racing license.
- N. Rider must be signed off by any valid club Racing Organization.
- O. To achieve expert plates a Racer must race as an Amateur and acquire enough “points” to advance on to an Expert plate with a sanctioned race organization.

### **Rider Gear Requirements - Hooligan GP Class**

- U. **Helmet** – DOT full-face helmet (no flip up style). The helmet should meet SNELL or BSI certifications. The helmet should not be more than 5 years old, and it should be undamaged. Normal wear and tear from general use and transport are ok, but a helmet that has been crashed in or that has been visibly damaged will not pass tech.
- V. **Suit** – 1 or 2-piece. If it is 2-piece, it must affix together via a zipper between the jacket and the pants.
- W. **Back Protector** – An aftermarket back protector is highly recommended, back protector must be a CE-approved foam insert at the minimum.
- X. **Gloves** – Gauntlet-style glove that provides full coverage over your wrists and overlaps your leathers. Gloves should be in good condition and without holes or damage.
- Y. **Boots** – Provide full ankle coverage. They may be worn under the legs of your pants only if your Race Suit pant legs are designed for this. Otherwise, your boots must fully overlap the pant legs on your suit.

For more information contact the BAGGER RACING LEAGUE.